

DDSS3

Instruction manual V1-3-05W



GETTING TO KNOW THE DDS3

As water injection is playing a more and more important role in power tuning, there is more need to have a "fail-safe" mechanism in place to prevent engine from damaging itself through excess heat causes the onset of detonation.

DDS3 is the latest version of the first popular "Dash Display System" launched in 2002. The unit has gone through many design modifications resulting in no less than six added features that will help you to tune your engine to an even higher level safely.

The unit is now comes in the form of a standard 52mm gauge format with high intensity led Bargraph display as standard (Super-bright Red or Hi-efficiency Blue). Adjustable backlit brightness for night driving. "Boost-window detection width" adjustment is much simpler to set than the previous model. A user selectable button is added for switching to higher boost level when water flow is detected. It can also be used to enable the third party Boost controller or a switching in a simple "Wastegate bleed valve" (optional).

The standard package comes with a "water level sensor" to cancel "high boost setting" and disable the Aquamist pump from working in dry conditions - preventing the seal from wearing unnecessarily and shortening its working life. Lastly, the unit comes with a "priming pump driver" that mirrors the Aquamist pump and allows remote water tank installation and prevents priming problems during hard acceleration and can improve the flow rate of the main pump to nearly 600cc per minute.

A purpose designed anti-static junction box with clear colour coded legends to assist error-free termination of wire from various sensors - 'rising clamp' terminal block design allows positive excellent electrical even after many repeated uses.

Contents:

Dash gauge	Page	
	3	DDS3 Function Diagram
	4	Installation
Flow sensor		
	5	Flow sensor
Junction Box		
	6	Junction Box Description
	7	Generic connection diagram
Other Sensor		
	9	System1s
	10	System2d
Wiring diagram		
	11	Float Sensor installation
		Wastegate bleed valve explained
	12	Other connections
Technical		
	12	Electrical/Mechanical Specifications
Appendix		
	14	Pin out and Wiring details
		Guarantee and Warranty

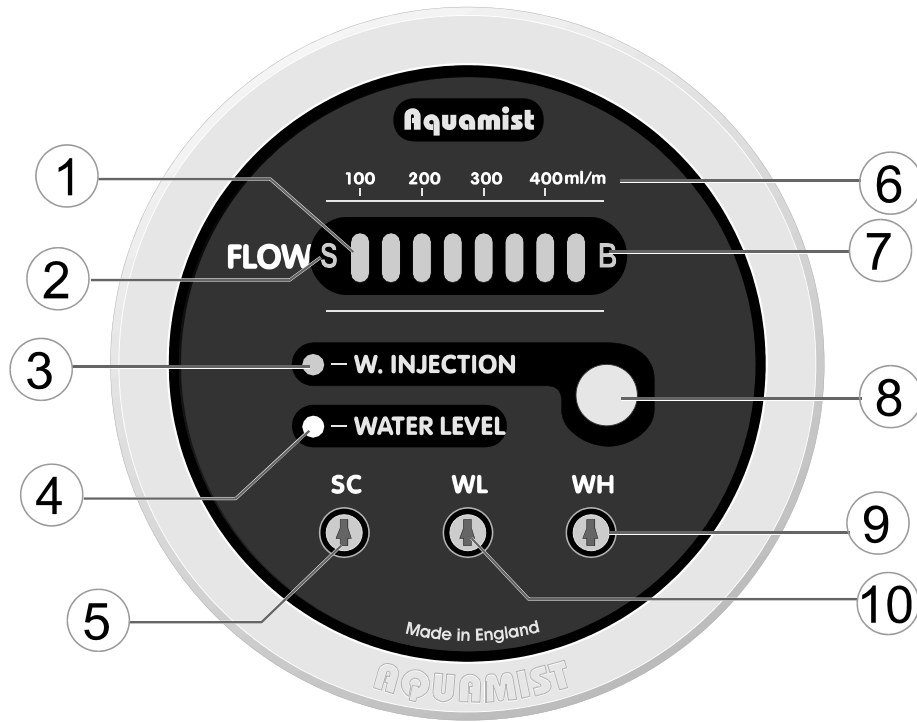

1. 8-element Bargraph Display (100-450ml/min)

Each segment is equivalent of 50ml/min. of flow if the sensor is calibrated in displaying absolute mode. Depends on user preference, the display can be scaled to suit the application - more explanation on "5".

2. "S" indicates the presence of sensor.

The letter "S" (sensor) must be lit after power up and stay on to shown the sensor is functioning correctly.

3. Water injection ON led

The led must be ON the when water injection is enabled by the "push button" on the gauge.

It will switch to full brightness when the MPS (Manifold Pressure Switch) is triggered.

4. Water Level Sensor led (yellow)

When the water level in the tank is below the sensor float lever, this led will light up and disables the water injection as well as any other related functions such as high boost, priming pump and main pump.

5. SC (Sensor Calibration)

20-stepped potentiometer allow user to scale the flow sensor to give an ideal visual indication of a given flow rate. Ideally set the full scale of the sensor about two/three segments below maximum so problem is easier to identify. It can also to trim the sensor accurately to show absolute values for a particular set up.

6. Backlit legend flow legend

Fixed scale to indicate absolute flow rate. Sensor must be calibrated for each application for accuracy.

7. "B" Boost Enabled led

This led lights up to show the "extended boost" over wastegate is enabled. Provided the following conditions are met: "Water Injection On" button is depressed, flow-rate is inside the set range and water tank is above the set level.

8. Water injection enable button

Due to extra power level achieved under WI, user want may want to reduce the power to the wheels in less than ideal driving conditions. Disable the WI will reduce boost to wastegate bleed valve setting (if fitted) as well as switching to a less aggressive MAP on custom engine management.

9. Over-range setting potentiometer

It is just as important to monitor over-range conditions as well as under-range flow conditions. If a leak is developed close to the water jet and starves the engine of the water, the user must know this condition. A 20-stepped potentiometer allows accurate and repeatable adjustment range.

10. Under-range setting potentiometer

This setting can indicate partial blockage and trapped air inside a delivery hose. Again a 20-stepped potentiometer is employed.

NOTE: The two range potentiometers "9" and "10" form the basis of a SOA (Safe Operating Area) that allow users to tune their car safer.

Please note that methanol has only 80% mass of water and 50% latent heat of water. If water and alcohol mix is injected, allow a bigger jet to compensate this. This is a common mistake often made. Every 25% of methanol added should allow a 0.1mm Increase of jet size diameter.

Installation

The gauge will fit into any 52mm gauge pod and a two-prong bracket is provided. Do not over-tighten the thumb-wheel since it is an embedded o-ring to create high friction between the surfaces thus preventing loosening due to vibrations.

An open ended 8-core DEF. standard cable is provided to connect the gauge to the DDS3 Junction box where all the other sensors and peripheral devices is terminated. We avoid using plugged termination because it is difficult to thread through the socket or plug pass a small opening.

All the core colours are coded and match to the legends in front of the terminal block to avoid any accidental termination errors. The wires should be stripped and twisted before inserting into the terminal blocks. The eight top left terminals are reserved for the DDS3 gauge.

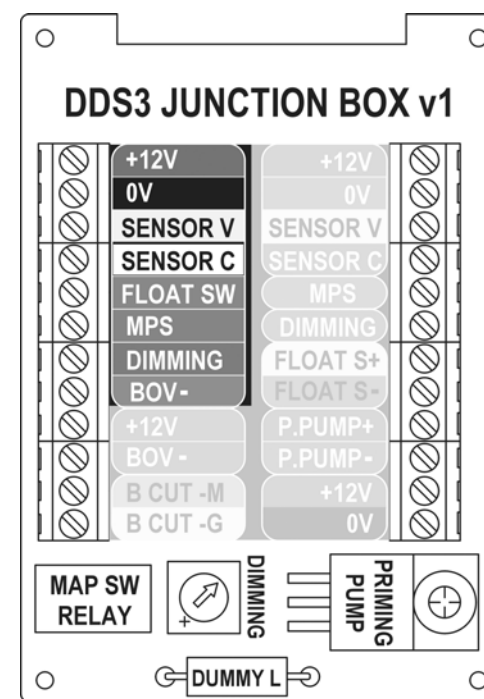

Flow Sensor

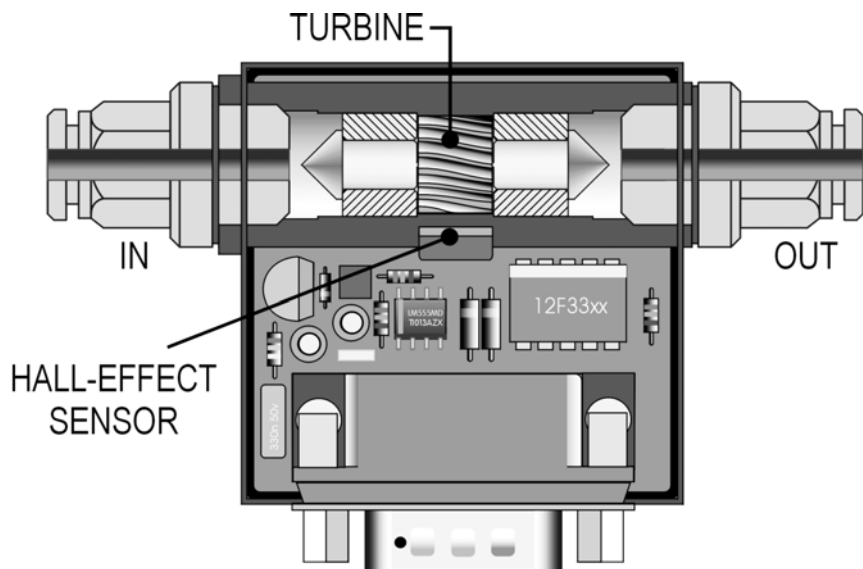

The sensor shown on the top is the result of a three-year intense development effort of our own design team. Pulses from the magnetised turbine are digitally translated by an internal micro-controller, giving an linearized output signal of 0-5V proportional to the water flow. The latest generation of sensors are fully re-programmable and can be updated with new development when necessary.

As the role of water injection become more intense in the modern tuning demand, a direct reading device is an absolute necessity, you cannot rely on passive sensors such as water level sensors and

inline pressure switches to detect blocked water jet anymore. In order to safeguard an engine running at full load, the sensor must be able to supply the ECU real-time flow information so alternative strategy can be put in place to offset of cooling loss through reduction of water flow.

The sensor consists of four wires: +12V and 0V as power and 0.5V-4.5V output for flow indication and an 5-0V input for Calibration. The four wire goes directly to the DDS3 Junction box as below highlighted on the left.

The appropriate connections are located on four terminals at the top right of the circuit board

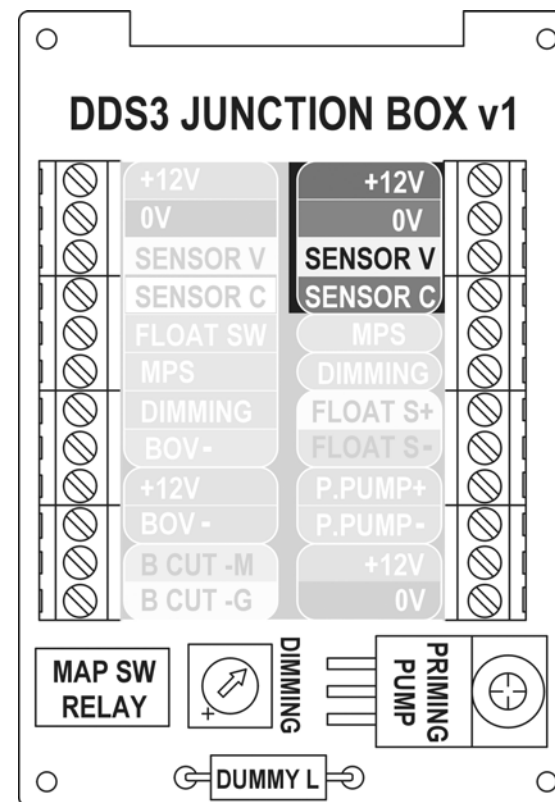

DDS3 Junction box

Introduction:

This is no ordinary junction box, It has active circuitry inbuilt channelling the correct information to the appropriate devices. It is also responsible for limiting the maximum current drawn by four devices. Diagram shows the different input and output pins of Junction Box.

Pin1-8

Legends are colour matched and connects directly to DDS3 Gauge via a 8-core cable.

Pin 9-10

It will activate a wastegate solenoid valve directly when correct water flow is detected (system on)

Pin 11-12

This relay output can be used to disconnect the OE boost control valve and switch to an "Dummy load resistor" to prevent "engine check lamp" activation. "Dummy Load Resistor"

can be removed by a pair of sniper (Bottom of the circuit board).

Pin 13-16

Flow Sensor connections, colour matched.

Pin 17

Manifold pressure switch connection (806-157) - normally closed. 10psi from factory.

Pin 18

To car's +ve side lamp circuit for dimming the display.

Pin 19-22

To float sensor and priming pump (up to 1A), use relay to increase current.

Pin 23

To switched +12V supply - 5A+

Pin24

To 0V, Battery negative or chassis ground. Must have good electrical contact.

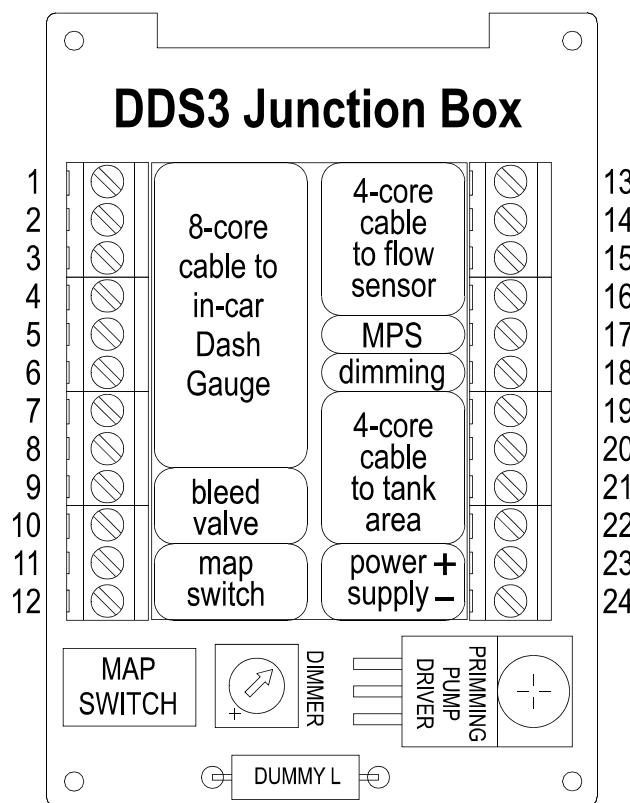

DDS3 -GENERIC CONNECTION DIAGRAM

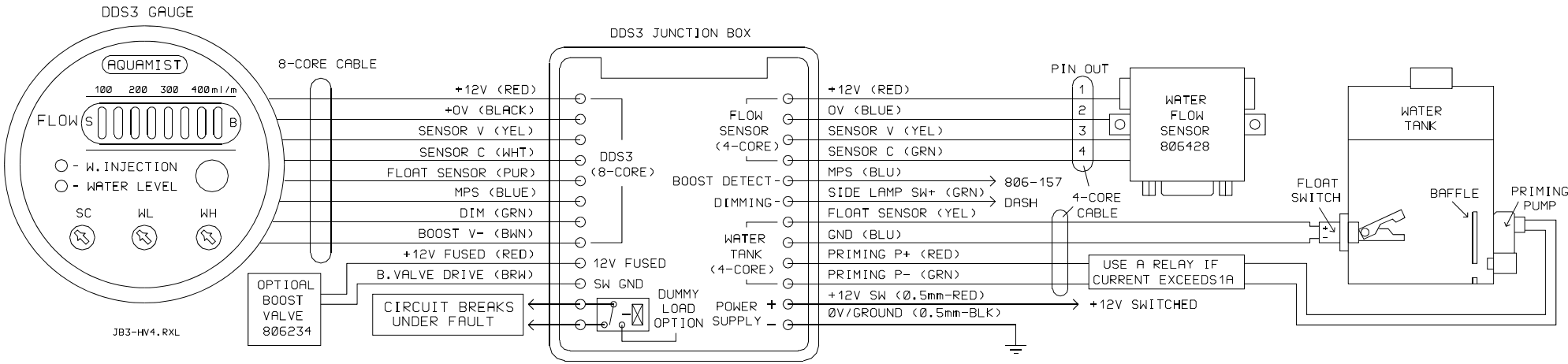

DDS3-System 1s

DDS3 INTERFACING WITH SYSTEM 1S WIRING DIAGRAM-HV5

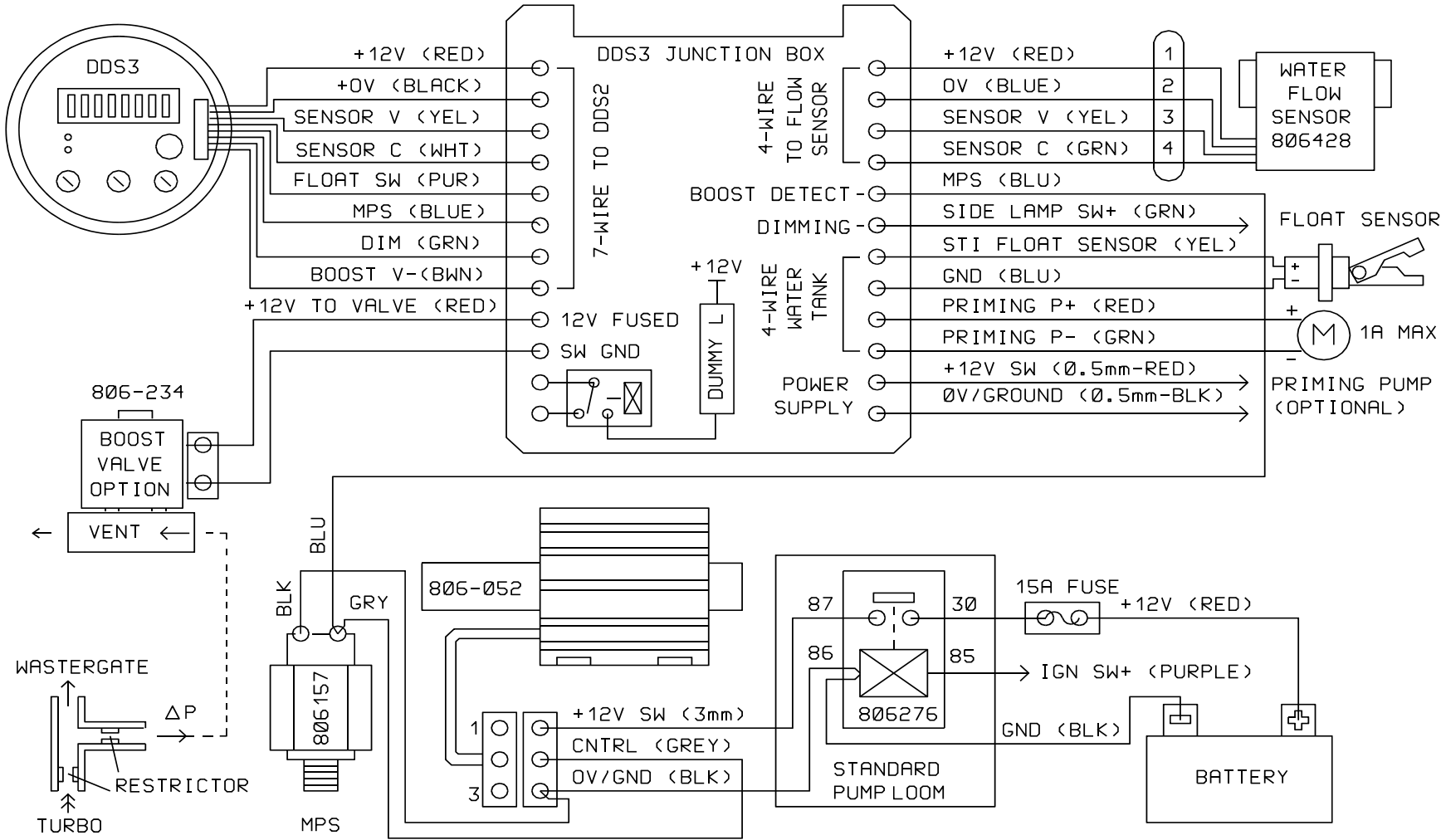

DDS3-System 2d

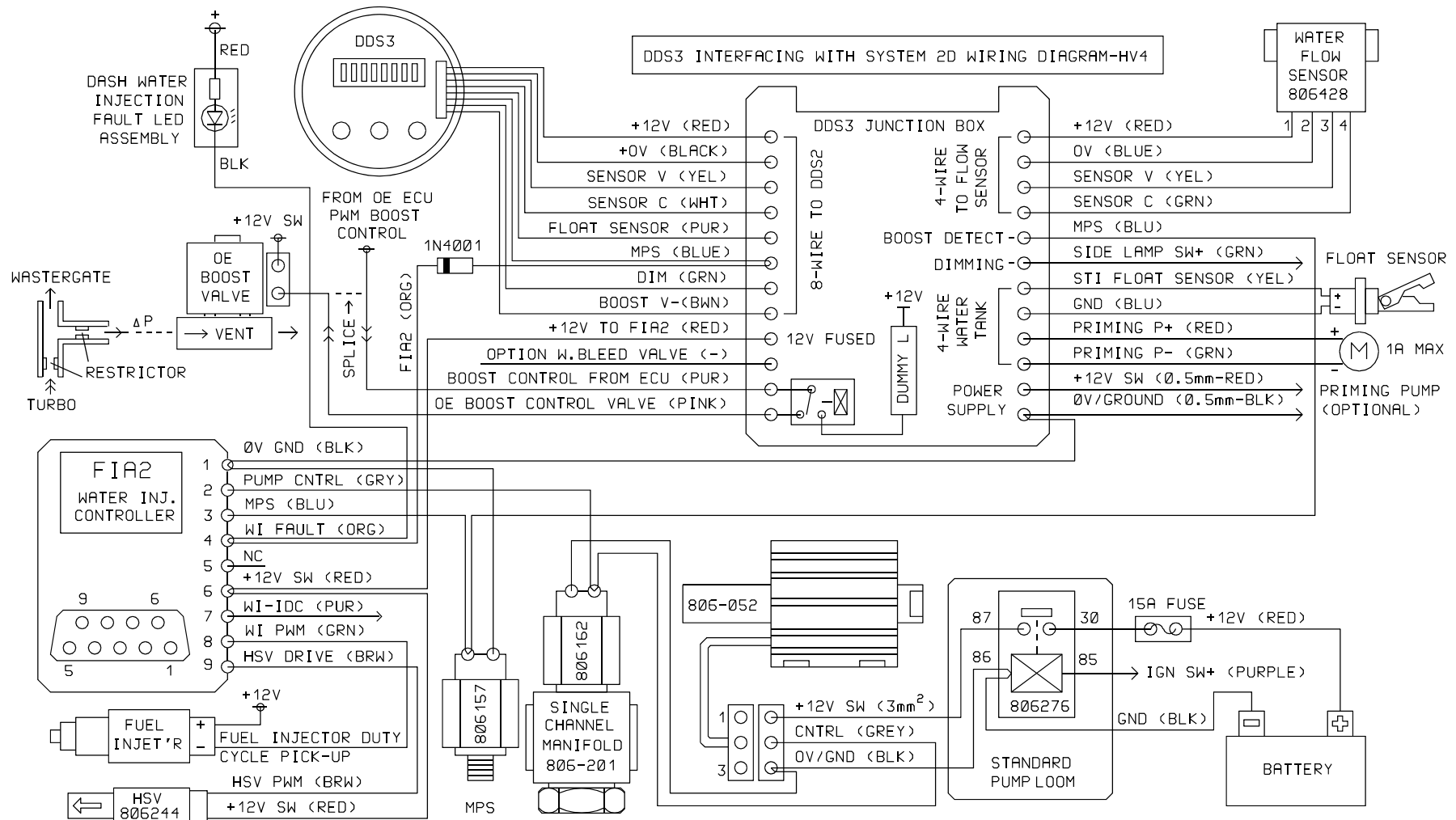

The above diagram shows the full connection of the DDS3 to System2d. It will require a 1N4001 diode. It combines all the features of the 2d as well as the DDS3. A high resolution version of this diagram can be downloaded on our website: <http://www.aquamist.co.uk>.

Float Sensor installation

The Float Supplied with the DDS3 is an external fitting type. A burr-free 22mm hole should be drilled on a flat surface approximately 30-40mm from the bottom. Insert the float end until the gasket flange in full contact of the external surface. Plastic washer must be place between the nut and gasket. Make sure the float swivels upwards before tightening the assembly. A spanner at the wire end will help achieving task easier.

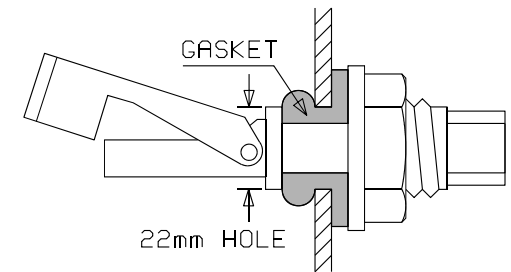

Wastegate bleed-off valve explained

There are several ways to raise boost pressure over factory's wastegate setting electrically. The simplest way is to insert a restricted Tee piece between the turbo outlet and wastegate. The restrictor (generally about 1mm) limits the air flow to the wastegate so when air is being vented at the T-junction, the wastegate is receiving less pressurised air and produce less travel. As a result, the boost is increased. The amount of boost raised is approximately the size ratio between the two restrictors. The end result has to be done experimentally due to mechanical variations between different turbo assemblies.

The DDS3 can raise the boost of your engine when a normally closed solenoid valve is energised electrically, allowing air to vent out of the T-junction. This active is totally automatic when the button on the gauge is pressed when water flow is detected and water level is still above the float sensor. The dotted lines on the diagram on the left can be replaced by a rubber tube so that the valve can be mounted remotely.

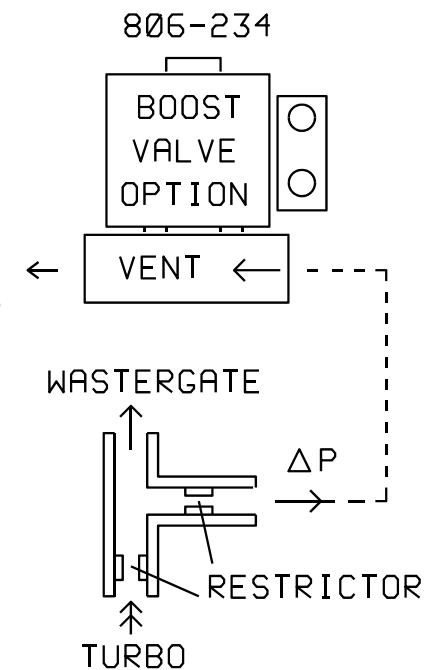

DDS3 Other ECU interface

In order to extract the maximum performance from an engine, one must tune towards an air/fuel ratio of around 12.5:1 and Ignition timing as close to MBT (maximum brake torque) timing.

The 12.5:1 air/fuel ratio is generally considered as "too lean" by many tuners for normal "fast road" applications. The common solution is to inject "excess fuel" and use it as a coolant. It is a fact that "over-rich" mixture is bad for power, the burn-rate is greatly affected by the production of carbon dioxide.

Water injection is a natural substance to replace "excess fuel" since it has six times the latent heat of gasoline if absence of water can be detected and instruct an ECU to change MAP or reduce boost.

The DDS3 is designed to interface with other engine controllers and devices directly. This will enable a WI injection system be integrated into most ECUs without any further user involvement.

Equipped with two outputs from the junction box, the DDS3 is able to cut fuel or reduce boost in the absence of water. The first output drives a wastegate solenoid valve directly at the "presence" of

water and the second output in the form of "circuit break" relay output in the "absence" of water.

Both outputs revert the ECU back to standard setting when the dash switch is switched off, water tank level is low and water flow is not within the set range.

The top two terminals drive a solenoid valve directly and allow the manifold pressure be raised when energised with water flow is detected.

The remaining two connections are "normally close voltage free" contacts, it will drop out just above the Manifold pressure switch opening point where water injecting would normally commence.

We can custom configure these outputs when requested. Please email us at: richard@aquamist.co.uk or post a note to our forum:

<http://www.aquamist.co.uk/phpBB2>

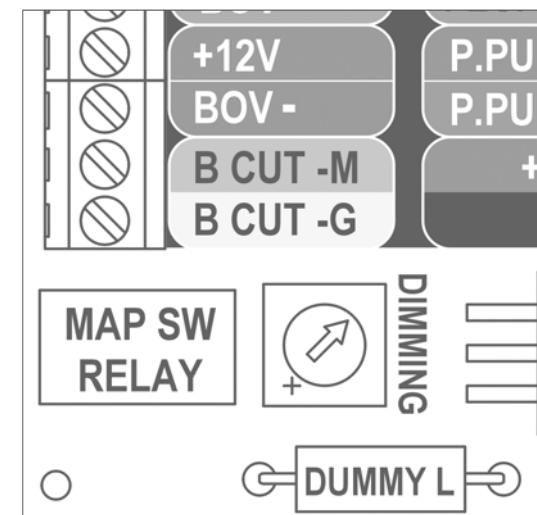

Electrical / Mechanical Specifications

DDS3-gauge

Input voltage: 11.5 - 14.5VDC
 Input current:
 Standby 25mA DC
 Full Brightness 250mA DC
 Flow Sensor input voltage:
 Presence 0.5V DC
 Flow 0.5 - 4.5V DC

 Manifold Pressure switch: Ground "off" activation

 Float Sensor Threshold: Ground active
 Sensor Calibrating Voltage: 5-0V DC
 Detection Window range:
 Low 0.5v to 2.5V DC
 High 2.5V to 5V DC
 Boost valve drive 1A max

 Water on led:
 Standby 5mA DC
 WI active 15mA DC
 Water level led: 15mA DC
 Boost enable led: 8mA max
 Bargraph led: 8mA per segment max
 Bargraph type:
 Red Super Bright Red
 Blue High efficiency

 Mechanical specifications:
 Dimensions 52mm x 45mm (H)

 Operating temperature range: 0-50C

Flow sensor

Input voltage: 10-15V DC
 Input current: 25mA DC
 Output Voltage: 0-5V DC
 Output current: 5mA max
 Dimensions: 40x 75 x 20mm(H)

Float sensor

Input voltage: 50VDC max
 Switch current: 100mA max
 Panel hole dimension: 22mm

Junction box

Input voltage: 11.5-15V DC
 Input current:
 Standby: 30mA DC

 Output currents:
 Priming .Pump: 1A DC max
 Boost valve: 1A DC max
 Boost cut relay 2A DC max
 Flow sensor 50mA max

 In circuit Fuse links:
 DDS3 gauge: 2A
 Priming pump: 2A
 Boost valve: 2A
 Flow sensor: 1A
 Dimensions: 75 x 57 x 17mm(H)

Appendix

In Car Dash Gauge (8-core cable)

Pin	Colour	Size	Description	Electrical parameter
1	Red	0.22	+12V power supply to gauge	50mA @12v
2	Black	0.22	0V power supply to gauge	50mA @12v
3	Yellow	0.22	Flow Sensor input voltage	0-5 VDC @10mA
4	White	0.22	Flow Sensor calibration output voltage	5-0 VDC @1mA
5	Purple	0.22	Float Sensor from water tank	Ground active
6	Blue	0.22	Manifold Pressure Switch (806-157)	Normally closed
7	Green	0.22	Night driving dimming connection	+12V active
8	Brown	0.22	Watergate bleed valve option (SW-)	1A @12V max.

Flow Sensor (4-core cable)

Pin	Colour	Size	Description	Electrical parameter
1	Red	0.22	+12V power supply of Flow Sensor	30mA @ 12v
2	Blue	0.22	0V power supply of Flow Sensor	0V Ground
3	Yellow	0.22	Flow Sensor output voltage	0-5VDC@10mA
4	Green	0.22	Flow Sensor calibration input voltage	5-0VDC@1mA

DDS3 Junction Box (24-ways - Pin 1= top left corner. Pin 24 bottom right corner)

Pin	Colour	Size	Description	Electrical parameter
1-8	-----		Same as Dash Gauge Above	-----
9	Red	0.22	+12V power supply to bleed valve	+12V, 2A fused
10	Brown	0.22	Switching to ground for Bleed valve	1A maximum
11	Pink	0.22	Boost cut relay wiper (ECU side)	1A maximum
12	Brown	0.22	B. Valve or (Dummy 33R Load option)	1A pulsed
13-16	-----	0.22	Same as Flow Sensor as above	-----
17	Blue	0.22	Manifold Pressure Switch (806-157)	Normally closed
18	Green	0.22	Night driving dimming connection	+12V active
19	Yellow	0.22	To ground when tank is empty	0.25A maximum
20	Blue	0.22	Common ground	0.25A maximum
21	Red	0.22	Priming pump +12V supply (2A FUSED)	1A maximum
22	Green	0.22	Priming pump ground switch (active)	1A maximum
23	Red	0.50	+12V switched power supply for all	3A maximum
24	Black	0.50	0V ground supply for all	3A maximum

Multicore core cable colour

GUARANTEE

ERL guarantees, at our option, to replace faulty goods supplied or repair the same, subject to the claim made in writing to us within 12 months after the sale by us, or for such other period as may be indicated by us for specific products in lieu of any warranty or condition implied by law as to the quality or fitness for any particular purpose of the goods.

Any claim against us must be made to us in writing within the period of 12 months after the sale by us, or our agents, or our distributors of goods in question (or such other period as may be indicated by us) and any goods to which the claim relates must be returned to us within that period suitably packaged and cleaned and, with any particular instructions which we may have notified to you at the time of supply. Original invoice, the nature of any claimed defect must accompany the goods in question prior to despatch to us.

If these requirements are not complied with our Guarantee shall not apply and we shall be discharged from all liability arising from the supply of defective goods.

LIABILITY

We shall not be under any liability whether in contract, or tort or otherwise and whether or not resulting from our negligence or that of our employees, in respect of defects in goods supplied or for any damage or loss resulting from such defects.

We shall not be under any liability for damage, loss of expense resulting from failures to give advice or information or giving the incorrect advice or information whether or not due to our negligence or that of our employees.

In no event shall any breach of contract on our part or tort (including negligence) or failure of any time on our part that of our employee give rise to liability for loss of revenue or consequential loss or damages arising from any cause whatsoever.

Note: ERL reserves the right to make changes to our products without notice in order to improve design performance and reliability.

ERL Ltd Irook House Bolney Ave Peacehaven East Sussex BN10 8HF England